

* US adapters 1/2" NPT supplied

** To add a secondary control to the thermostatic valve, the blanking disc will need to be removed to expose the 1/2" thread. The blanking disc is sealed so may need to be gently warmed to remove.

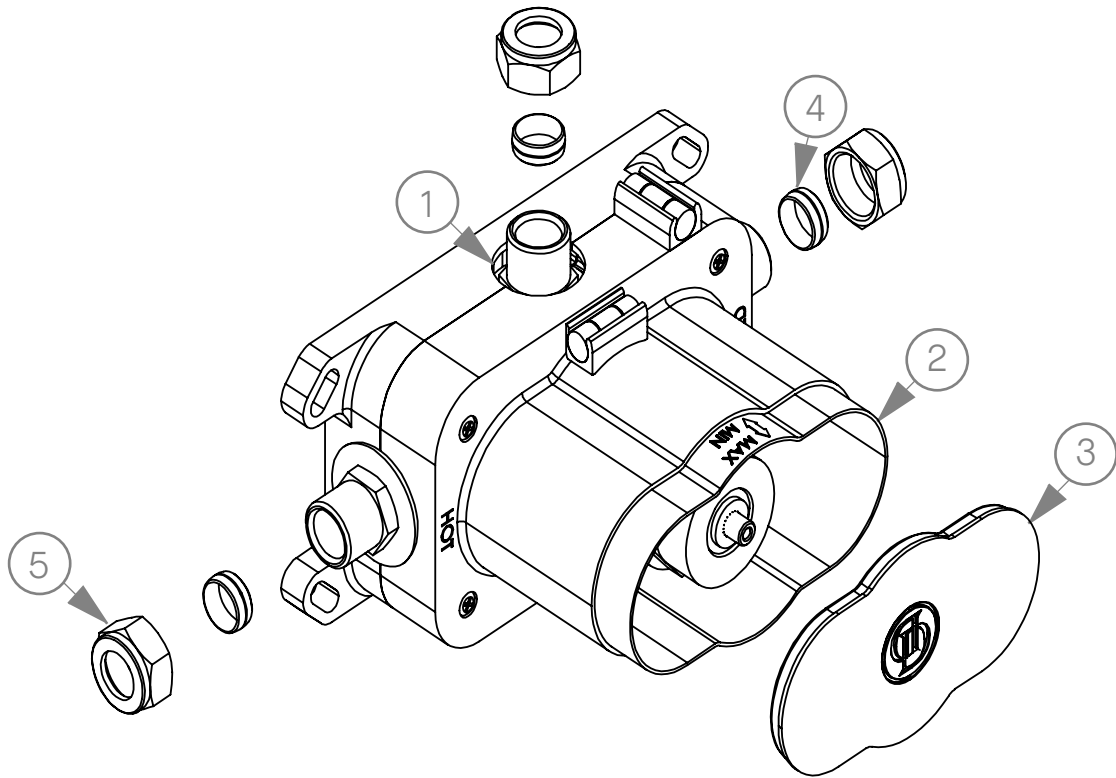

| # | ROUGH IN COMPONENTS | QTY |
|---|---------------------|-----|
| 1 | Thermostatic Valve | 1 |
| 2 | Plastic Cover | 1 |
| 3 | Plastic Cap | 1 |
| 4 | Olive | 3 |
| 5 | Nut | 3 |

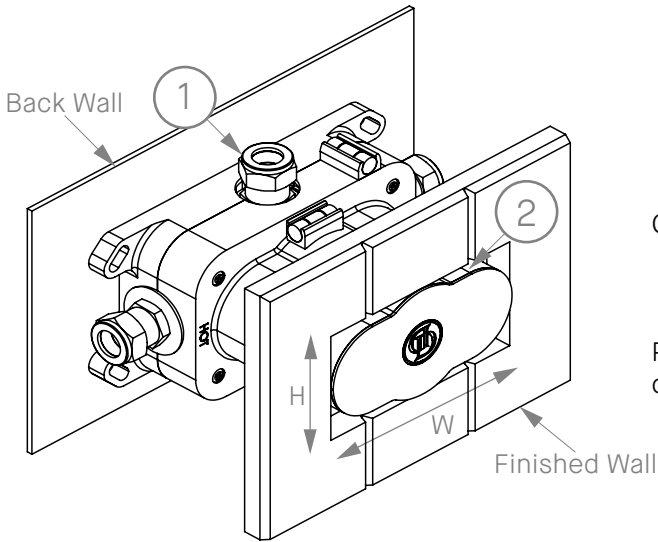
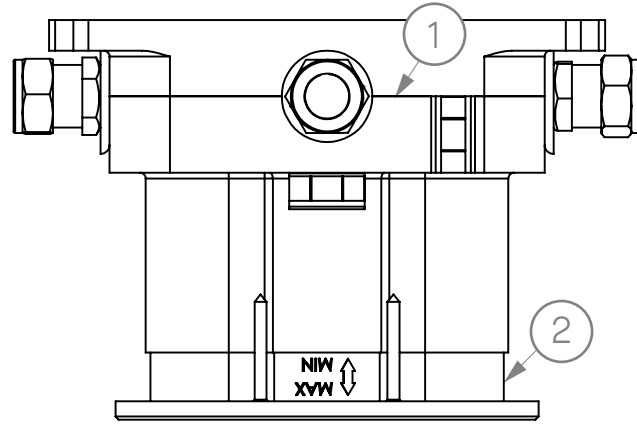
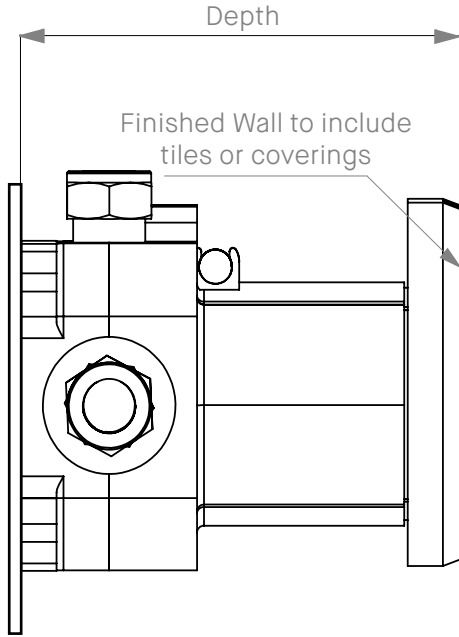

1. Install thermostatic valve (1) onto the back wall. Cut the plastic cover (2) using the Max and Min indicated on the cover as a guide. Ensure that the depth including the finished wall is within tolerance - see table below.

Plumb in the valve using olives and nuts (4 and 5), test and check for leaks (please ensure the isolation valves are fully open when testing).

| COMPATIBLE TRIM SET CODE | TRIM SET DESCRIPTION | ROUGH IN DEPTH AND TOLERANCE TO FINISHED WALL | H x W WALL CUT OUT |
|--------------------------|---|---|--|
| DAD1686 | Leawood Thermostatic Shower Valve | MIN: 109mm / 4-5/16" MAX: 125mm / 4-15-16" | HEIGHT: 64mm / 2-1/2" WIDTH: 117mm / 4-5/8" |
| DAD1860 DAD1861 | Bestwood Lever Thermostatic Valve Bestwood X Head Thermostatic Valve | | |
| DAD1930 | Chessleton Thermostatic Valve | | |
| DAD1944 | Mull Classic Thermostatic Valve | | |
| DAD1970 | Dalby Concealed Thermostatic Valve | | |
| DAD1973 | Coll Lever Thermostatic Shower Valve | | |
| DAD1984 DAD1985 | Hudson X Head Thermostatic Shower Valve Hudson Lever Thermostatic Shower Valve | | |

IMPORTANT

It is vital that the rough in is installed to the depth and tolerance to the finished wall as indicated in the table above. Finished wall includes screeding, tiling and any wall coverings. Failure to install the rough ins to the correct tolerance will result in the trim set controls not fixing correctly.

Please ensure that the rough in is tested prior to closing the wall.

Drummonds Thermostatic Shower Valves are rated to TMV2 standards and have been tested against BS EN 1287 and BS EN 1111. They are designed to operate within a dynamic pressure range of 1.0 and 5.0 bar. In general, the higher the water pressure, the greater the flow of water through the valve.

PLEASE NOTE:

The flow rate is dictated by the on/off or diverter valve selected, not the shower rose, shower arm or spouts. For 2 and 3 way diverters, flow rates will be based on the main outlet.

If adding a secondary outlet, it will have a slightly lower flow rate.

Please refer to the relevant information below:

| DAD1931 ON/OFF CONTROL | | |
|---------------------------|-----------------|---------------------|
| Pressure | Litres / Minute | US Gallons / Minute |
| 0.5 | 9.26 | 2.45 |
| 1 | 13.76 | 3.64 |
| 1.5 | 17.27 | 4.56 |
| 2 | 19.88 | 5.25 |
| 2.5 | 22.48 | 5.94 |
| 3 | 24.66 | 6.51 |
| 3.5 | 26.68 | 7.05 |
| 4 | 28.71 | 7.58 |
| 4.5 | 30.45 | 8.05 |
| 5 | 32.17 | 8.50 |

| DAD1932 ON/OFF 2 WAY DIVERTER | | | | |
|----------------------------------|-----------------|---------------------|------------------|---------------------|
| Pressure | Main Outlet | | Secondary Outlet | |
| | Litres / Minute | US Gallons / Minute | Litres / Minute | US Gallons / Minute |
| 0.5 | 8.62 | 2.28 | 7.85 | 2.07 |
| 1 | 12.44 | 3.29 | 11.18 | 2.95 |
| 1.5 | 15.46 | 4.08 | 13.85 | 3.66 |
| 2 | 17.96 | 4.74 | 16.04 | 4.24 |
| 2.5 | 20.2 | 5.34 | 18.14 | 4.79 |
| 3 | 22.08 | 5.83 | 19.78 | 5.23 |
| 3.5 | 23.92 | 6.32 | 21.52 | 5.68 |
| 4 | 25.62 | 6.77 | 12.13 | 6.11 |
| 4.5 | 27.23 | 7.19 | 24.51 | 6.47 |
| 5 | 28.6 | 7.56 | 25.97 | 6.86 |

| DAD1934 ON/OFF 3 WAY DIVERTER | | | | |
|----------------------------------|-----------------|---------------------|------------------|---------------------|
| Pressure | Main Outlet | | Secondary Outlet | |
| | Litres / Minute | US Gallons / Minute | Litres / Minute | US Gallons / Minute |
| 0.5 | 8.33 | 2.20 | 7.45 | 1.94 |
| 1 | 11.81 | 3.12 | 11.01 | 2.91 |
| 1.5 | 14.62 | 3.86 | 13.69 | 3.62 |
| 2 | 17.04 | 4.50 | 15.82 | 4.18 |
| 2.5 | 19.08 | 5.04 | 17.84 | 4.71 |
| 3 | 21.02 | 5.55 | 19.4 | 5.12 |
| 3.5 | 22.68 | 5.99 | 21.1 | 5.57 |
| 4 | 24.31 | 6.62 | 22.57 | 5.96 |
| 4.5 | 25.79 | 6.81 | 23.91 | 6.32 |
| 5 | 27.26 | 7.20 | 25.26 | 6.67 |

Flow rates have been measured under laboratory conditions and in accordance with the recommended installation parameters, with a balanced dynamic pressure (bar) recorded at the shower valve inlet. External factors such as pipework, connectors and bathroom design may affect the information provided.

DYNAMIC V STATIC PRESSURE

Static pressure is the water pressure that exists at a fitting when no flow is taking place (tap is in closed position).

Dynamic pressure is measured with the valve open and the water flowing.
As a result the Dynamic pressure will be a lower figure than the static pressure.

Whilst a tap is in the closed position, the static pressure may be 3 bar, however once the tap is open the pressure may drop to 0.8 bar or less, as the supply pressure fluctuates.

Ref. www.bathroom-academy.co.uk

NOTES:

UK Handshowers are fitted with a 12 l/m flow restriction
US Handshowers are fitted with a 1.8 g/m flow restriction
US Shower Arms are fitted with a 2.0 g/m flow restriction

To achieve optimal performance from your shower rose, we would recommend the following minimum flow rates for each Drummonds' shower rose.

Please refer to the applicable flow rate information when considering your shower set up and valve combination.

| Shower Rose | Minimum Flow Rate |
|--|-----------------------------------|
| <p>DAD1914A 130mm 5" Classic</p> <p>DAD1914EC 200mm 8" Classic Easy Clean</p> <p>DAD1923 Adjustable</p> | <p>12 L/M 3.17 US Gallons</p> |
| <p>DAD1903EC 300mm 12" Classic Easy Clean</p> <p>DAD1914 200mm 8" Classic</p> <p>DAD1920 Ceramic Tear Drop</p> <p>DAD1925 200mm 8" Grand</p> | <p>18 L/M 4.75 US Gallons</p> |
| <p>DAD1903 300mm 12" Classic</p> <p>DAD1926 300mm 12" Grand</p> | <p>24 L/M 6.34 US Gallons</p> |