

* US adapters 1/2" NPT supplied

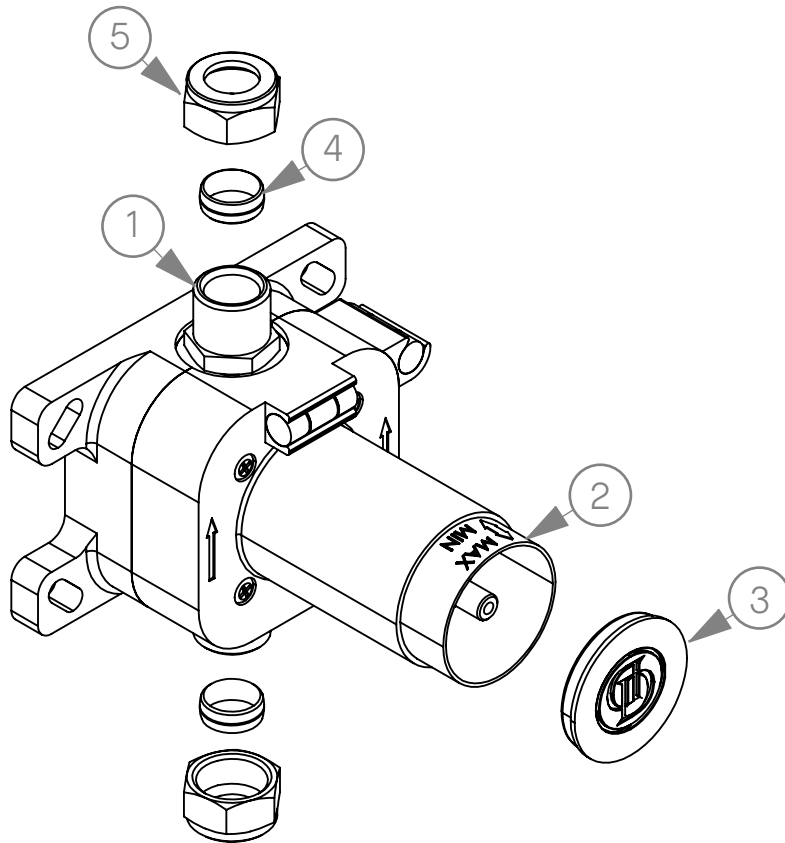

#	ROUGH IN COMPONENTS	QTY
1	On/Off Valve	1
2	Plastic Cover	1
3	Plastic Cap	1
4	Olive	2
5	Nut	2

INSTALLATION INSTRUCTION

DAD1931

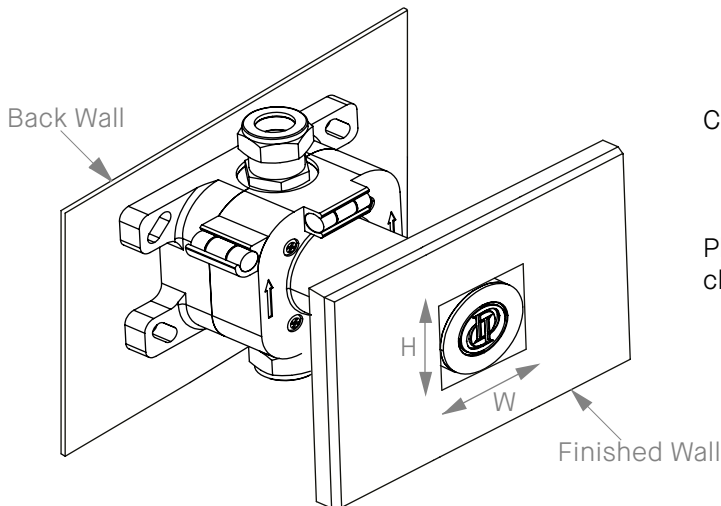
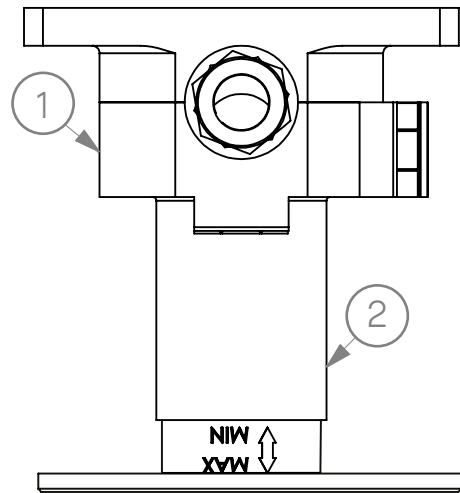
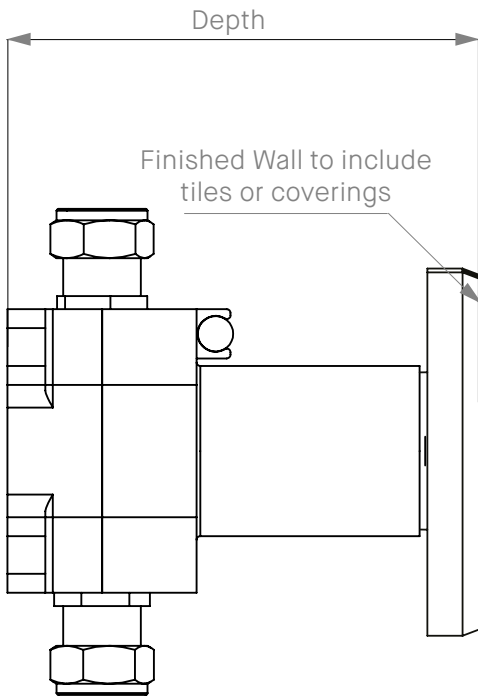

1. Install On/Off valve (1) onto the back wall. Cut the plastic cover (2) using the Max and Min indicated on the cover as a guide. Ensure that the depth including the finished wall is within tolerance - see table below.

Plumb in the valve using olives and nuts (4 and 5), test and check for leaks (please ensure the isolation valves are fully open when testing).

COMPATIBLE TRIM SET CODE	TRIM SET DESCRIPTION	ROUGH IN DEPTH AND TOLERANCE TO FINISHED WALL	H x W WALL CUT OUT
DAD1687	Leawood On/Off Control	MIN: 109mm / 4-5/16" MAX: 125mm / 4-15/16"	HEIGHT: 45mm / 1-3/4" WIDTH: 45mm / 1-3/4"
DAD1862	Bestwood Lever On/Off Control		
DAD1863	Bestwood X Head On/Off Control		
DAD1931	Chessleton On/Off Control		
DAD1945	Mull Classic On/Off Control		
DAD1971	Dalby Concealed On/Off Control		
DAD1974	Coll Lever On/Off Control		
DAD1986 DAD1987	Hudson X Head On/Off Control Hudson Lever On/Off Control		

IMPORTANT

It is vital that the rough in is installed to the depth and tolerance to the finished wall as indicated in the table above. Finished wall includes screeding, tiling and any wall coverings. Failure to install the rough ins to the correct tolerance will result in the trim set controls not fixing correctly. Please ensure that the rough in is tested prior to closing the wall.

FLOW RATES

DAD1931

Drummonds Thermostatic Shower Valves are rated to TMV2 standards and have been tested against BS EN 1287 and BS EN 1111. They are designed to operate within a dynamic pressure range of 1.0 and 5.0 bar. In general, the higher the water pressure, the greater the flow of water through the valve.

PLEASE NOTE:

The flow rate is dictated by the on/off or diverter valve selected, not the shower rose, shower arm or spouts. For 2 and 3 way diverters, flow rates will be based on the main outlet.

If adding a secondary outlet, it will have a slightly lower flow rate.

Please refer to the relevant information below:

DAD1931 ON/OFF CONTROL		
Pressure	Litres / Minute	US Gallons / Minute
0.5	9.26	2.45
1	13.76	3.64
1.5	17.27	4.56
2	19.88	5.25
2.5	22.48	5.94
3	24.66	6.51
3.5	26.68	7.05
4	28.71	7.58
4.5	30.45	8.05
5	32.17	8.50

Flow rates have been measured under laboratory conditions and in accordance with the recommended installation parameters, with a balanced dynamic pressure (bar) recorded at the shower valve inlet. External factors such as pipework, connectors and bathroom design may affect the information provided.

DYNAMIC V STATIC PRESSURE

Static pressure is the water pressure that exists at a fitting when no flow is taking place (tap is in closed position).

Dynamic pressure is measured with the valve open and the water flowing.
As a result the Dynamic pressure will be a lower figure than the static pressure.

Whilst a tap is in the closed position, the static pressure may be 3 bar, however once the tap is open the pressure may drop to 0.8 bar or less, as the supply pressure fluctuates.

Ref. www.bathroom-academy.co.uk

NOTES:

UK Handshowers are fitted with a 12 l/m flow restriction
US Handshowers are fitted with a 1.8 g/m flow restriction
US Shower Arms are fitted with a 2.0 g/m flow restriction

To achieve optimal performance from your shower rose, we would recommend the following minimum flow rates for each Drummonds' shower rose.

Please refer to the applicable flow rate information when considering your shower set up and valve combination.

Shower Rose	Minimum Flow Rate
<p>DAD1914A 130mm 5" Classic</p> <p>DAD1914EC 200mm 8" Classic Easy Clean</p> <p>DAD1923 Adjustable</p>	<p>12 L/M 3.17 US Gallons</p>
<p>DAD1903EC 300mm 12" Classic Easy Clean</p> <p>DAD1914 200mm 8" Classic</p> <p>DAD1920 Ceramic Tear Drop</p> <p>DAD1925 200mm 8" Grand</p>	<p>18 L/M 4.75 US Gallons</p>
<p>DAD1903 300mm 12" Classic</p> <p>DAD1926 300mm 12" Grand</p>	<p>24 L/M 6.34 US Gallons</p>