

TECHNICAL DRAWING

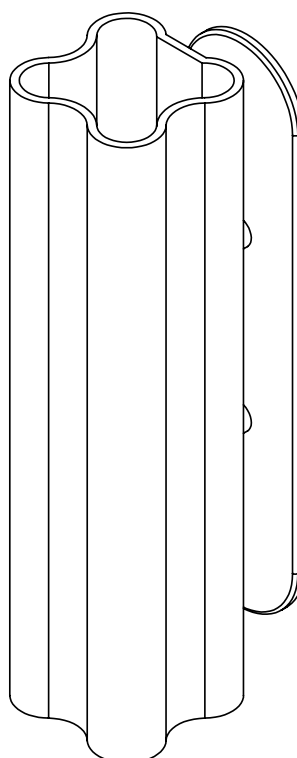
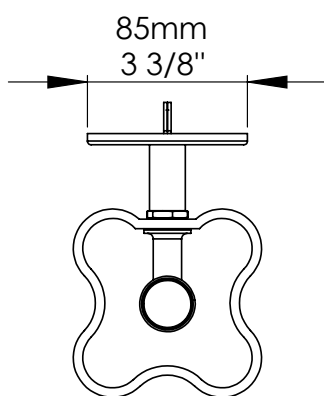
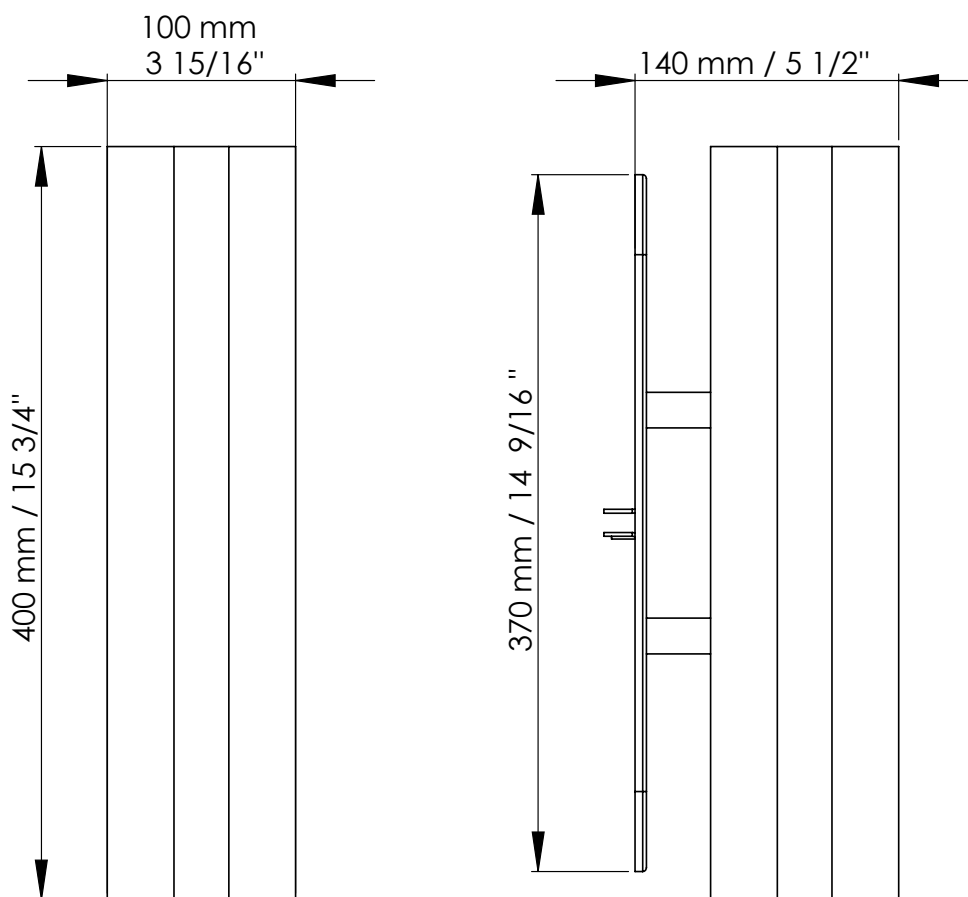

DELIVERY & STORAGE INSTRUCTIONS

TAKING DELIVERY OF YOUR PRODUCTS

- Sign for delivery confirming the number of pallets/boxes received and move products into property or storage area
- Open boxes and wooden crates and check that all components are included in accordance with product drawing
- Check for any damage to the products that may have occurred during transportation
- In accordance with our terms and conditions, report in writing, any damage or missing products within 3 days of delivery.

PROTECTING YOUR PRODUCTS ON SITE

- Taps and fittings should be stored in their original packaging, in a clean and dry environment, at normal room temperature. After inspection, please ensure products are clean and dry before returning to original packaging.
 - Baths should be removed from their wooden crate and stored in a clean environment at normal room temperature. It is very important to protect the bath from damage, in particular the interior enamelled surface and exterior polished surface. Do not put any masking tape onto the exterior of the bath.
 - Towel rails should be removed from their wooden crate and stored in a clean, dry environment at normal room temperature. It is very important that the plated surface of the towel rail is kept clean and dry. Dust, dirt or moisture that is allowed to sit on the plated surface will result in tarnishing, which can permanently damage the product invalidating the guarantee.
 - China sanitaryware should be stored in its original packaging and protected against breakage.
 - Marble should be removed from the wooden crate for inspection and then stored in a clean environment on its long edge, making sure that it is protected against damage.
 - Please follow the care instructions below if you need to clean the products being careful not to use any abrasive or chemical cleaners.
-

PREPARING FOR INSTALLATION

- All water fittings should only be installed by a qualified plumbing engineer and comply with current water regulations. Products and connections should remain accessible for routine maintenance. We recommend that isolation and non-return valves are fitted in all installations where appropriate.
- For some of Drummonds' products, in particular cast iron baths, you will need to ensure that you have sufficient people on site to help with the careful lifting of the product.
- Read and follow the installation instructions below and check that you have all of the parts and tools required to install the product properly.
- Drummonds offer a selection of pipework fittings kits to ensure that all visible feeder and waste pipes are installed in the same finish as your Drummonds product. Please contact us if you require assistance specifying the correct kit, which can be delivered in advance of your main order to tie in with your plumbing engineer's first fix.
- Take all necessary precautions to ensure that all parts are properly protected during, and after, installation. Polished and plated surfaces are particularly prone to damage from dirty and incorrect tools; spanners should be suitably lined so as to not damage plated or polished nuts.
- Drummonds' bath and basin taps are designed to operate at up to 3 bar water pressure. Where water pressure exceeds 3 bar, we suggest pressure reducing valves are fitted. For optimum performance, hot and cold water pressure should be correctly balanced.
- To avoid damage to tap or shower cartridges flush your existing hot and cold water system to ensure there is no debris or dirt in the existing pipework prior to commencing installation.
- A build-up of limescale is inevitable on all water fittings and, for hard water areas, we recommend the fitting of a suitable water treatment device.
- When using sealant, only a suitable neutral curing sealant should be used.
- After installation, please ensure the product is operating correctly, that it is clean (in accordance with cleaning instructions below) and protected until completion of all works in the property.
- If you, or your plumbing engineer, require any further advice please call us on the number below.



BLOW OUT DRAWING

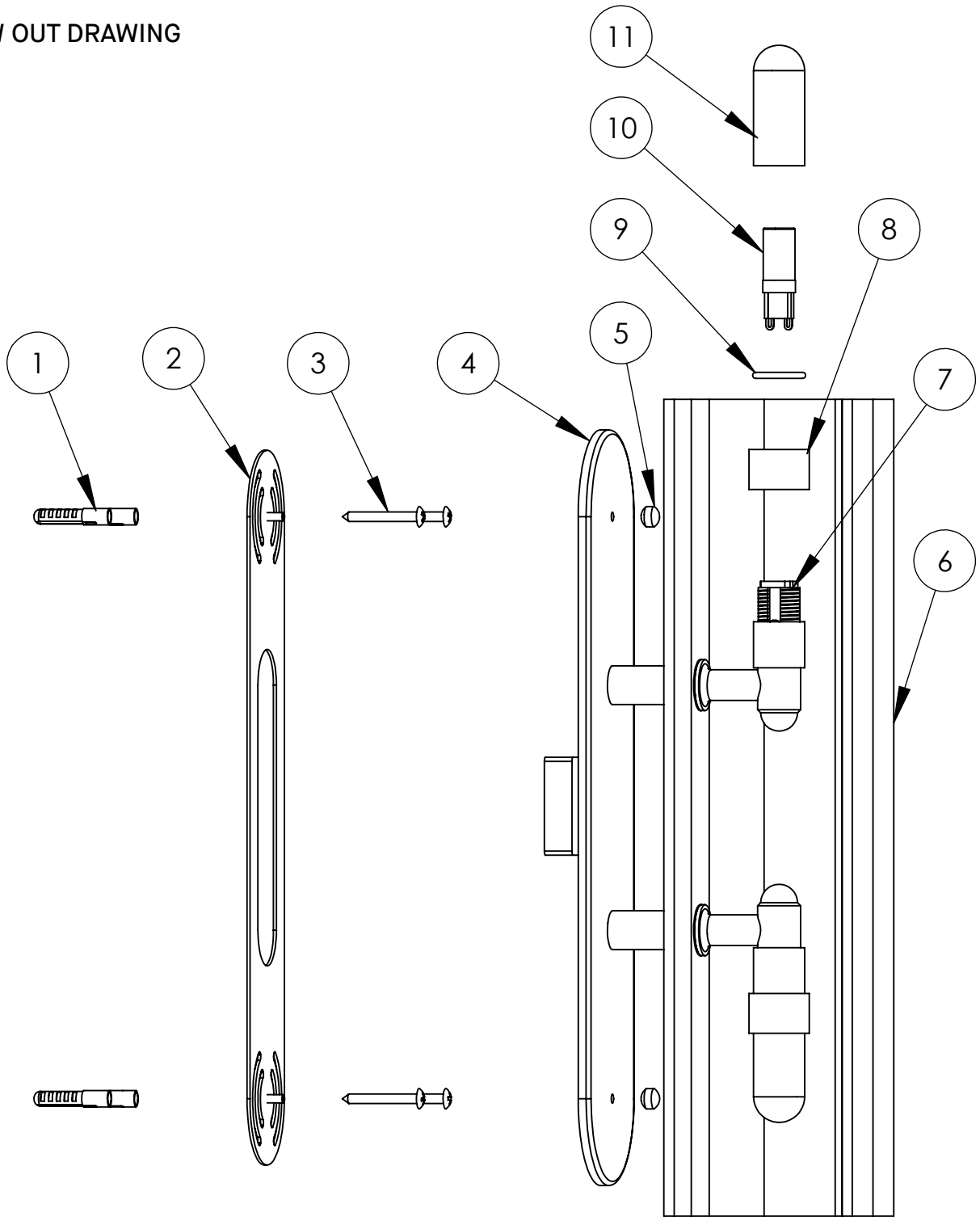

#	NAME	QTY
1	Raw Plug	4
2	Bracket	1
3	Screw	4
4	Lamp Body	1
5	Fixing Nut	2
6	Shade	1

#	NAME	QTY
7	Ceramic Lamp Holder	2
8	Metal Cover	2
9	O-Ring	2
10	G9 Led Bulb (not supplied)	2
11	Glass Bulb Cover	2



INSTALLATION INSTRUCTIONS

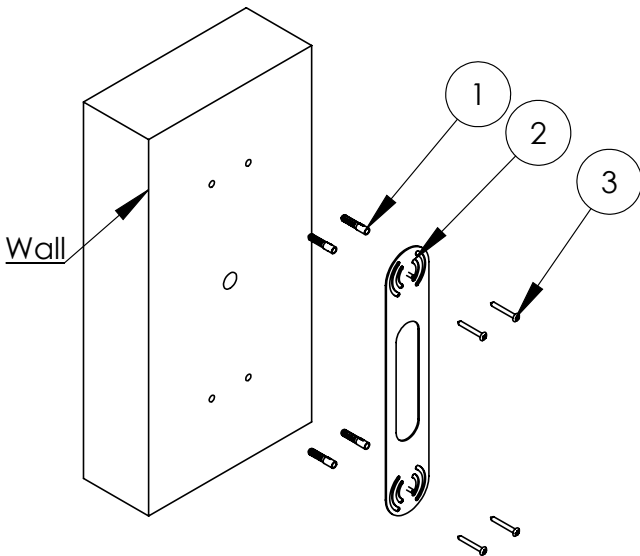

1. Place the bracket (2) to the wall. Ensure bracket is level, then mark and drill the holes. Set the Rawl Plugs (1) in the wall. Level the bracket (2) and screw it to the wall with the screws (3).

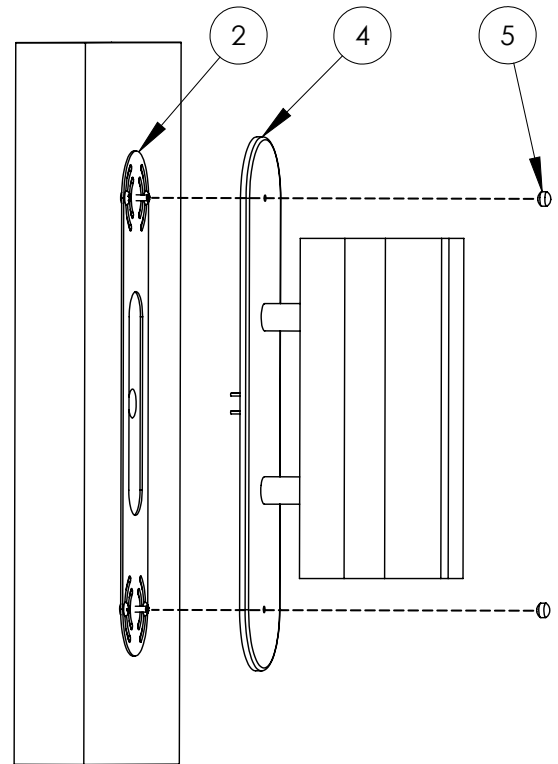



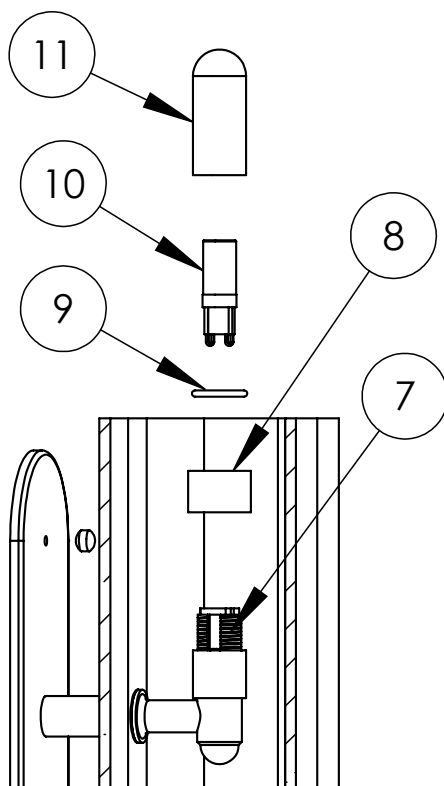

2. Connect the electrical wiring to house installation (diagram on the next pages). Fix the Lamp body (4) to the previously prepared bracket (2) with fixing nut (5).



3. Ensure the O-Ring (9) and metal cover (8) are in position in the lamp holder. Place your G9 LED bulb (10) in the ceramic lamp holder (7). Secure the glass bulb cover (11) onto the ceramic lamp holder (7)

WARNING! LIGHTS CAN GET HOT IN USE!	CLASS 1 LIGHT FITTING / IP44 RATED (240V)
ELECTRICAL WORK IN BATHROOMS MUST BE CARRIED OUT BY A QUALIFIED ELECTRICIAN	

1. Before starting the electrical work or connecting your light you will need to switch off your power supply at the fuse box (consumer unit). Either the miniature circuit breaker (MCB) can be turned off for the circuit for your light and applying **RED** insulating tape over the MCB to prevent it from being accidentally turned on. Or the main switch can be turned off, the circuit fuse removed, and the main switch turned on again to restore power to the rest of the house.
2. Colour code for fixed wiring:

GREEN/YELLOW	- Earth		
BROWN	- Live (introduced 2004)		Live (Pre 2004 colour code) RED 
BLUE	- Neutral (introduced 2004)		Live (Pre 2004 colour code) BLACK 
BLUE with brown sleeving	- Switch wire with sleeving (introduced 2004)		

NOTE: Some luminaires may have a clear cable. In this case, the earth wire will be marked with a green/yellow thread.
3. CLASS I Luminaires (Earthed) Fig 1 - connect the brown wire from the luminaire to the supply live wire (red or brown). Connect the blue wire to the supply neutral wire (black or blue). Connect the green/yellow wire to the supply earth wire (green/yellow) or connect the supply earth to the luminaire earth terminal marked 
4. Fix the luminaire to mounting surface making sure that no wires are trapped or damaged. Wires must be routed away from hot metal surfaces and not laid onto the back plate.
5. Fit all grommets supplied to protect wiring from any sharp edges.

If there is insufficient space within the luminaire for a terminal block then any connections must be made in the ceiling or wall space within a connection box. If no terminal block is included, installation may require advice from a qualified electrician.

6. Fit the correct wattage and type of lamp (bulb). We recommend you turn off the power before removing the lamp. This fitting is suitable for a G9 LED bulb (not supplied). Halogen bulbs should not be used due to possible high product temperatures that can result. Safety shields, where supplied. MUST be used.
7. Where applicable, fix glass securely to the luminaire. If screws are used to secure the glass, ensure that the glass is not stressed by over-tight screws. The screws should be finger tight. Be aware of sharp edges when handling glass and light fitting internals. Use the protective pads between glass and frame where supplied.
8. Re-connect the electricity supply and switch on. Enjoy your new luminaire.
9. Luminaires marked with this symbol  must not be disposed as domestic waste. Your retailer or Civic Amenity Site will advise.

NOTES: Plastered, painted or papered surfaces must be completely dry before installation to avoid the possibility of damage or discolouration to the luminaire. If there is any doubt that the surface may be damp, we recommend that a thin film of polythene is placed between the luminaire and mounting surface. This film can be removed when the surface is completely dry. Clean by using a soft, dry cloth. Do not use abrasives or metal polish. Some luminaires with low energy or low voltage lamps are not suitable. If in doubt, contact your lighting supplier. Some low voltage luminaires with toroidal (doughnut-shaped) transformers can cause the lighting circuit breaker to trip if it is too sensitive. If this happens, the MCB may need to be uprated with a type 'C' MCB - Check with your electrician. This is NOT a fault with the light fitting. If the luminaire uses G9 mains lamps, for safety, re-place only with a reputable branded lamp. Luminaires with external flexible cables, if damaged, shall be replaced by Drummonds or a qualified person to avoid a hazard. Any alterations to the luminaire or internal wiring will void the manufacturers' warranty. Do not mix switch start ballasts and High Frequency electronic ballasts on the same circuit. Improper selection, or improper use of the products and / or systems referred to and described herein or related items can cause personal injury or property damage, Drummonds Bathrooms Ltd. does not assume responsibility and disclaims liability for damage, loss, or expense arising from improper use, operation, or installation of this product.

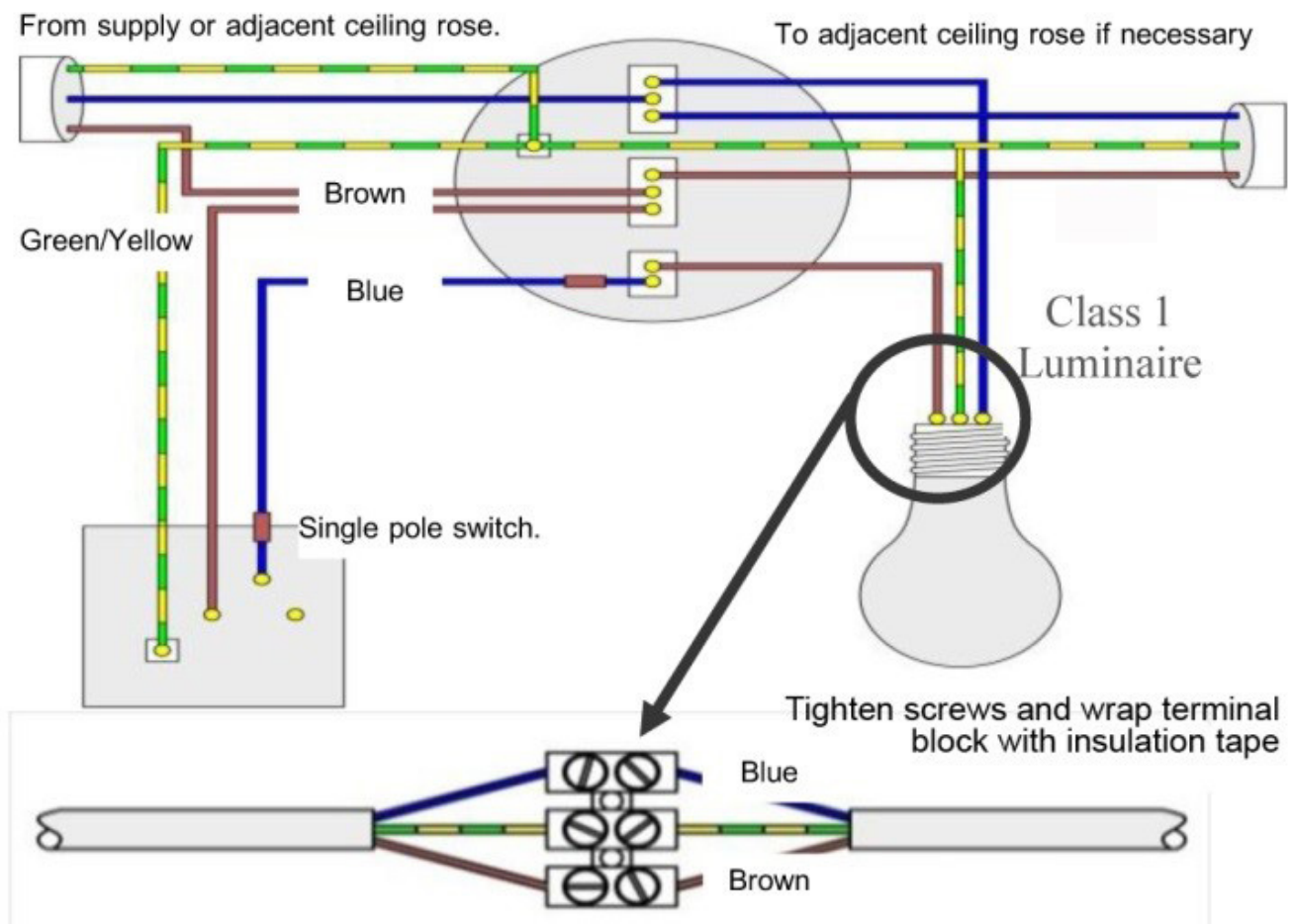

10. Guide to Bathroom Lighting Zones Figs 8 & 9

Electrical work in bathrooms must be carried out by a qualified electrician.

Full details of regulations can be found in the latest copy of the IEE wiring regulations.

Bathrooms are divided into Zones. These Zones are determined by the closeness of water and humidity and the likelihood of the light fitting getting wet. Bathroom light fittings are given an IP rating, which relates to these zones. The first digit of an IP rating describes its protection from solid objects such as gravel, insects and other dust. The second digit relates to its protection from moisture, which is directly relevant to the bathroom. The higher the number, the more protection it has.

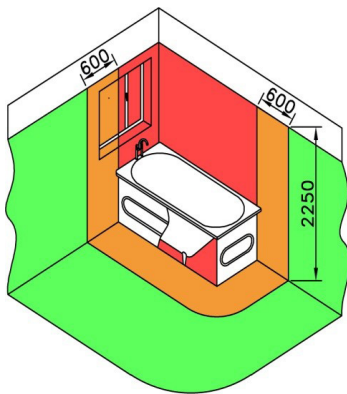

- **Bathroom Zone 0** - is the inside of the bath tub or shower basin. (IP68 submersible) Suitable for saunas, steam rooms or may be mounted underwater.
- **Bathroom Zone 1** - (IP65 water jet proof) Should be fitted where the fitting may be subjected to a jet of water, for example from a shower head.
- **Bathroom Zone 2** - (IP44) Should be fitted wherever the fitting may be splashed, anywhere within 0.6 meters of a basin or similar water source.

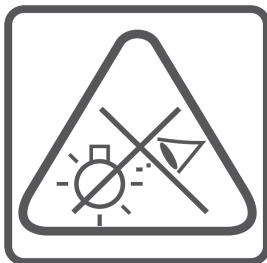
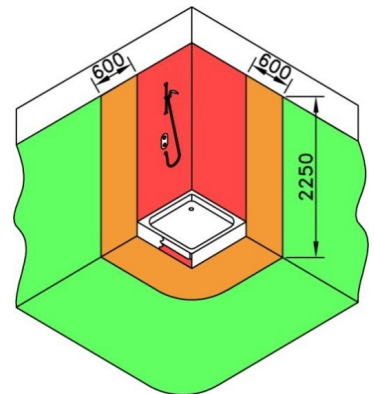

Do not stare at a working light source

CARE & MAINTENANCE

A Drummonds' bathroom product is designed to give you years of faultless service and, if you follow the instructions below, will continue to look stunning for many years. All Drummonds' bathroom products are guaranteed for 1 year from the date of purchase against manufacturing defects. The guarantee does not cover faults caused by incorrect installation, neglect, misuse, wear & tear, inappropriate cleaning or damage caused by the build-up of limescale. Please see Drummonds' terms and conditions for further details of the product guarantee.

GENERAL USE

To help prevent limescale build-up and water marks, all surfaces should be wiped dry after use. Only mild, non-abrasive cleaning products should be used followed by rinsing and drying with a soft cloth.

POLISHED BRASS PRODUCTS

All Drummonds taps and fittings are made from 100% brass, which can be supplied in a polished finish that is not lacquered. Polished brass will tarnish very quickly, especially in the bathroom where it is exposed to moisture. If you wish to maintain a shiny brass finish, regular polishing with an appropriate metal polish such as Brasso will be required.

POLISHED CHROME OR NICKEL PRODUCTS

Wipe off any water marks after use with a soft cloth or towel. Clean on a regular basis with a mild non-abrasive bathroom cleaner, again taking care to dry the product with a soft cloth or towel. For stubborn stains, particularly in hard water areas, remove with Brasso. Nickel products will require periodic polishing with Brasso, otherwise they will develop an aged patina similar to silverware.

SHOWER HEADS AND ROSES

Clean and descale on a regular basis, paying particular attention to the holes in the shower head to ensure that they don't become blocked. Remove and clean the thermostatic cartridge on a periodic basis to prevent permanent damage from limescale.

CAST IRON BATHS AND SHOWER TRAYS

The interior of a Drummonds' bath or shower tray is enameled with dry frit vitreous enamel which is very hardwearing and durable. To maintain the soft shine on the surface of the enamel rinse the bath out after each use, making sure that you get rid of any gritty deposits, and then dry it with a soft cloth or towel. To remove marks or dirt use a non-abrasive bathroom cleaner which is safe for use on enameled surfaces (please see the Vitreous Enamel Association website for guidance on suitable cleaners www.vea.org.uk). It is very important to ensure that a dripping, or leaking, tap is repaired immediately to prevent the enamel being permanently damaged.

BATH EXTERIOR

Caring for the exterior of your bath or shower tray is dependent on the finish of your bath:

- A raw, primed or painted exterior does not require any particular maintenance, other than occasional cleaning to maintain the appearance. If the exterior becomes scratched, exposing the cast iron below, it must be treated immediately with a suitable rust inhibitor, followed by a metal primer and paint finish to seal the exterior.
- A polished and lacquered exterior is a beautiful finish but it must be treated very carefully to avoid scratching especially when moving the bath into position. If the exterior does become scratched, please call Drummonds immediately so that we can advise on the best course of action. In general use the polished exterior should simply be wiped down with a soft cloth. Never use any kind of bathroom cleaner on the exterior of your bath. Care should also be taken when cleaning the floor around the bath, particularly with a skirted bath, not to allow floor cleaner to splash or rub on the bath, as it may damage the lacquer which protects the bath from rusting.

CHINA SANITARYWARE

Clean on a regular basis with a mild, non-abrasive bathroom cleaner to prevent the buildup of dirt and limescale. Ensure that dripping taps are repaired quickly to avoid the surface of the china becoming stained.

MARBLE VANITY BASINS

A Drummonds' marble vanity basin is a natural product which is hand polished and sealed in the factory. Clean the surface of the marble after use using a soft cloth, making sure that you dry the surface to prevent water marks developing on the marble. We would recommend Lithofin Easy Care which is a daily cleaner / conditioner designed for natural stones. Under no circumstances use any kind of bathroom cleaner, or limescale remover, on the surface of the marble. To prevent staining, it is important to ensure that any cosmetics, including shampoo, are wiped off the surface of the marble immediately.

WOODEN LOO SEATS

Clean after use with a damp soft (non-abrasive) cloth and dry immediately. Never use a bathroom cleaner on your loo seat as this is likely to strip off the varnish invalidating the guarantee. Use a high quality furniture wax polish occasionally such as Mylands Wax - Natural and apply in accordance with the manufacturers' instructions. Under no circumstance stand on your loo seat. Replace bumpers when perished as these can mark and stain the toilet seat.

